

TECHNICAL DRAWING PACKAGE

the
**ISLAND
PACKET**
32

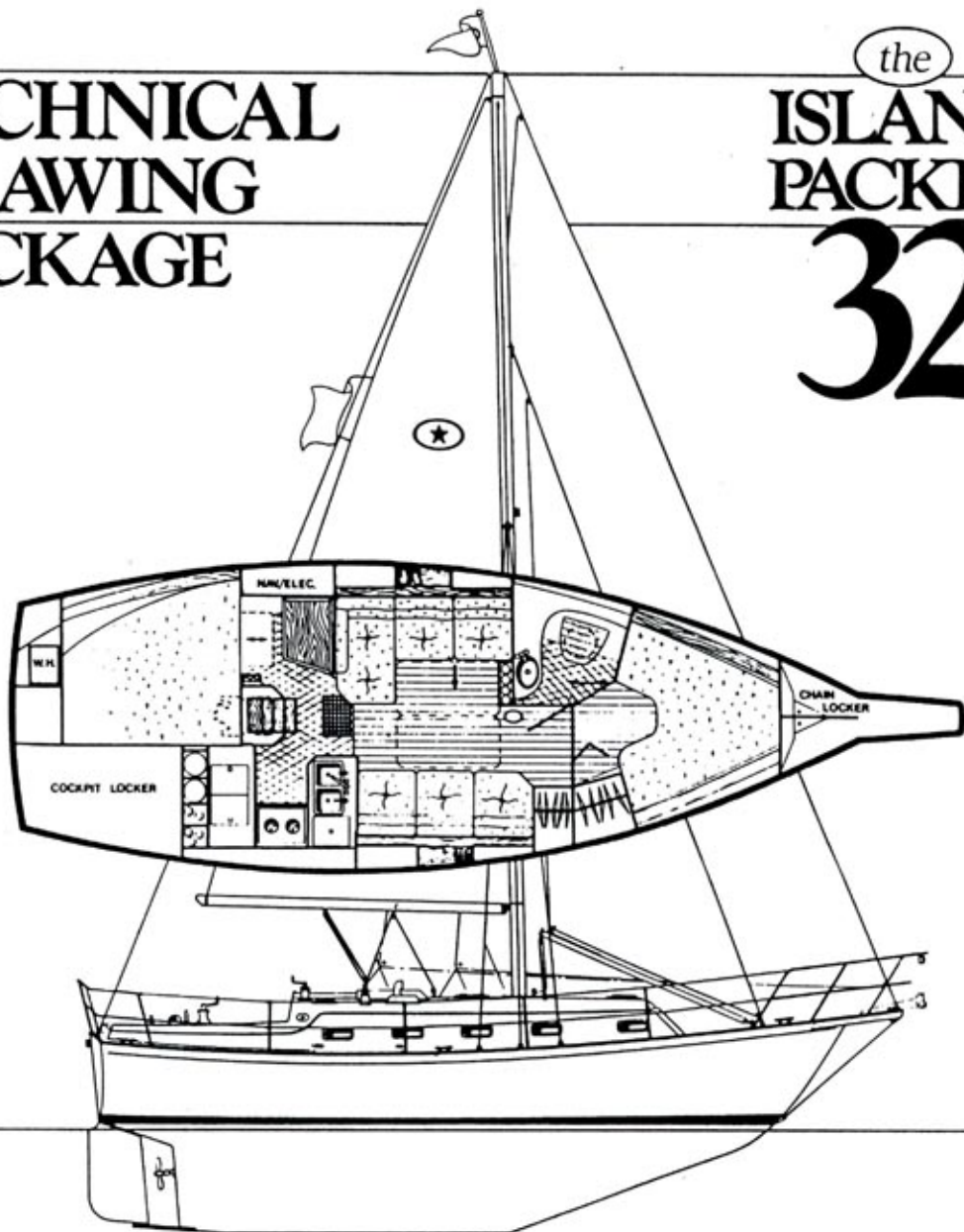

LOA	35'0"	Displacement (Approx.)	12,900 lbs
LOD	32'5"	Ballast	5,950 lbs
LWL	28'7"	Sail Area (100% ET.+STYS'L)	654 S.F.
Beam	11'6"	Auxiliary Power	27 HP FWC diesel
Draft	4'4"	Headroom	6'4"
Keel/CB (Opt.) Board Up	3'6"	Water Capacity	85 gallons
Board Down	7'2"	Fuel Capacity	28 gallons
Mast Above DWL	45'0"	Cabins / Berths	3 / 7

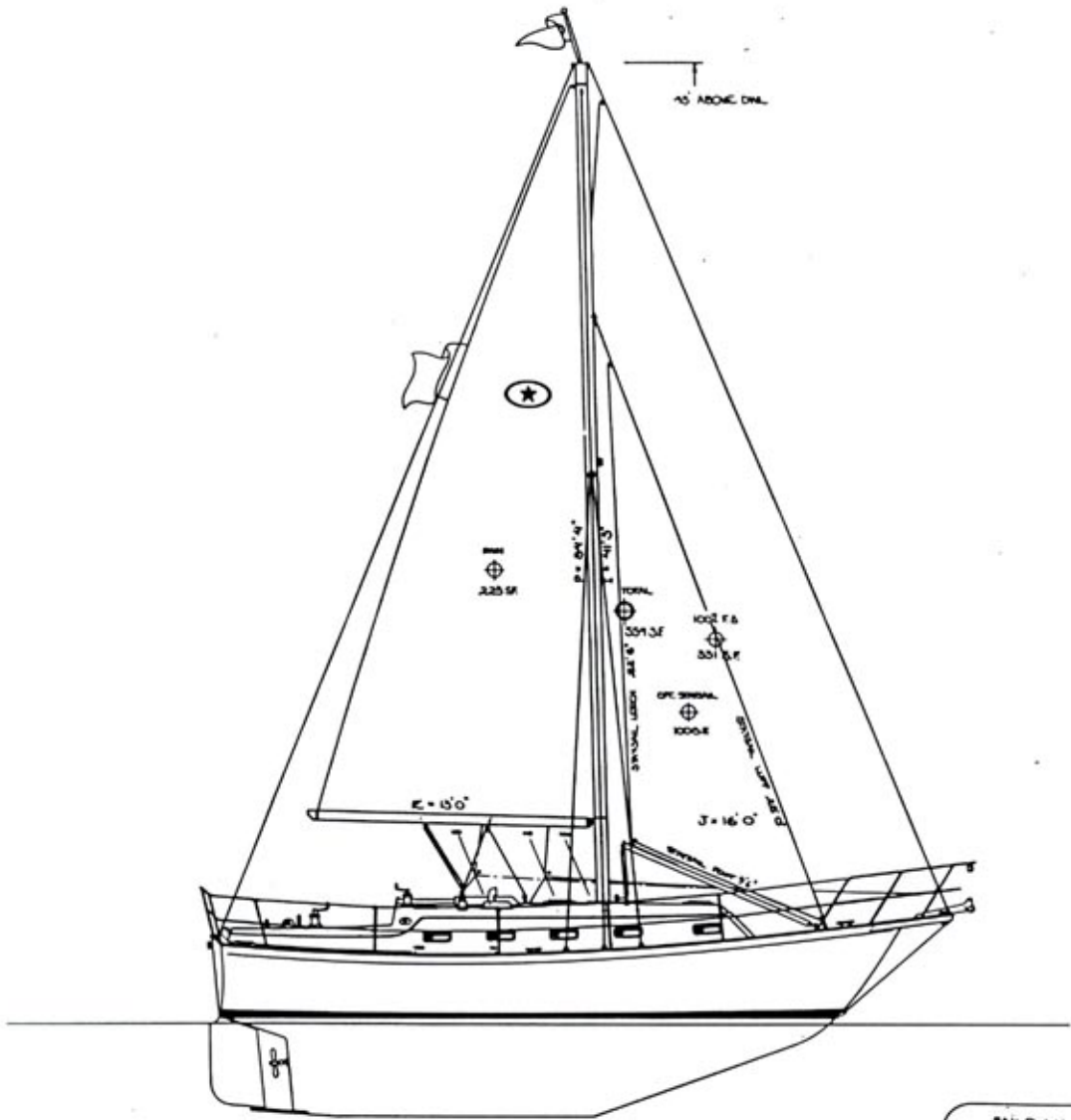

SAILPLAN
 ISLAND PACKET 32
 DIMS: L^T 32; 1000; S^T 11' 0"
 DATE: 1/80
 DESIGNER: BOB JOHNSTON, N.A.

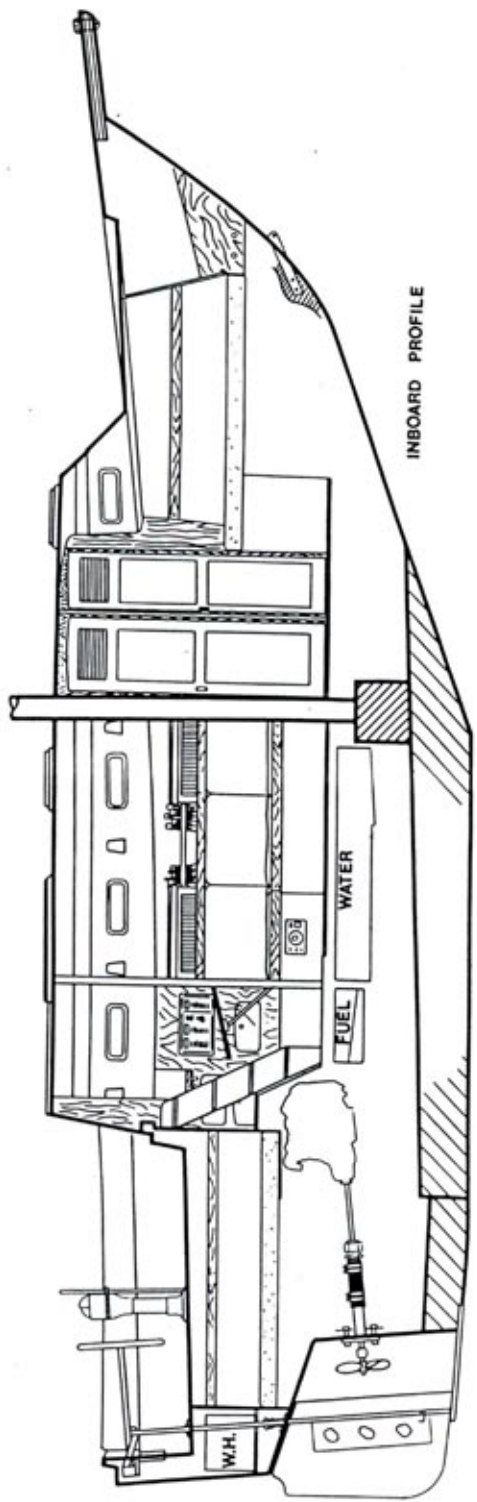
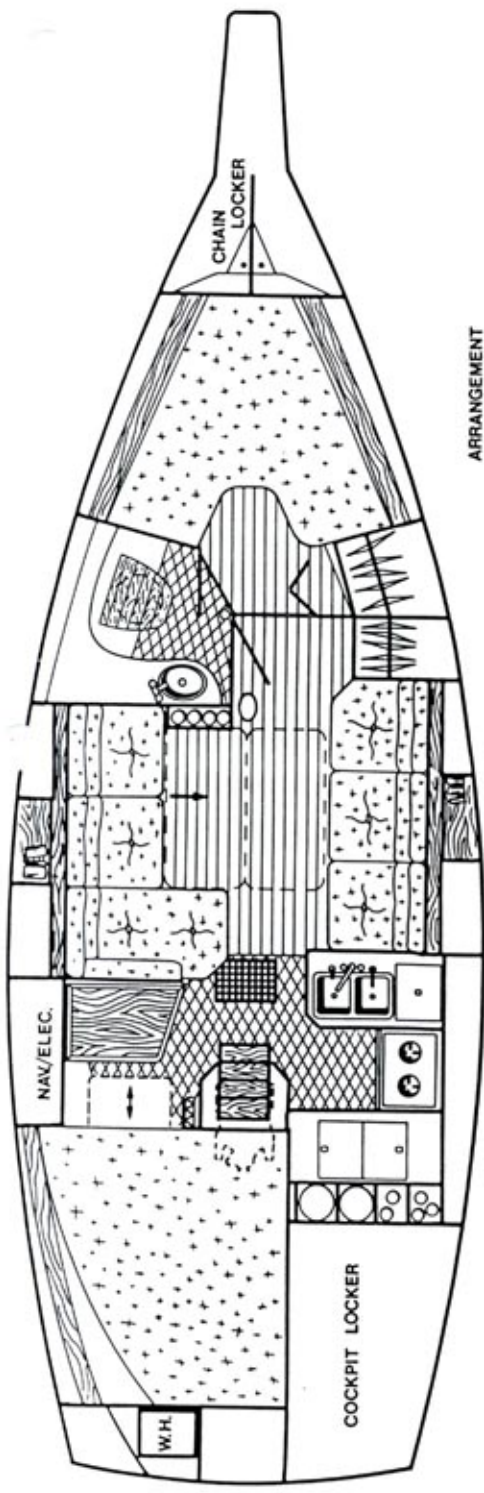

DECK PLAN
ISLAND PACKET 32

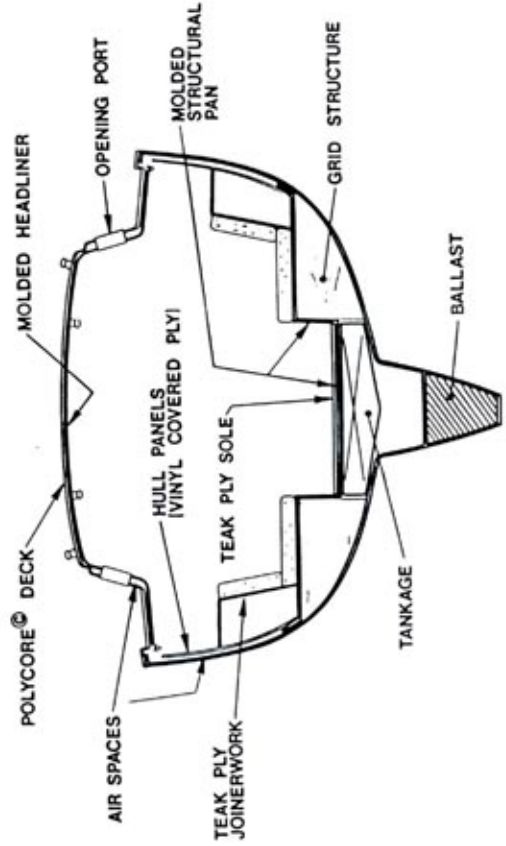
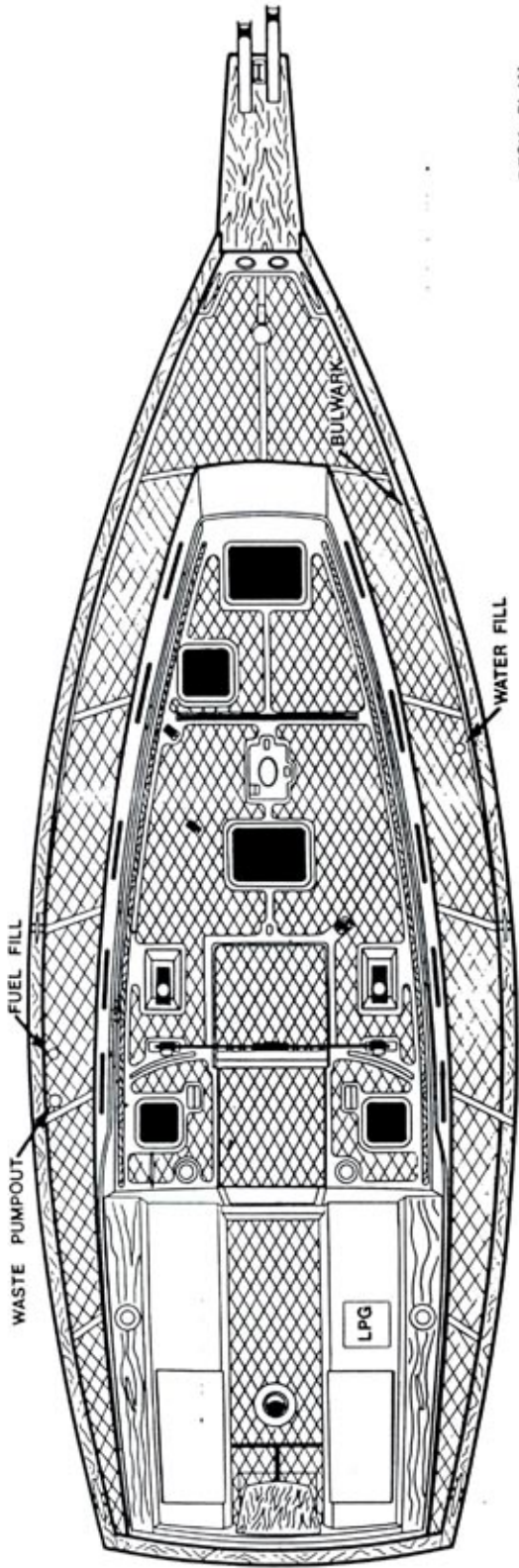

TYPICAL SECTIONAL VIEW

BASIC AC PANEL SCHEMATIC

BREAKERS:

- (A) MAIN AC
- (B) PORT OUTLETS
- (C) STBD. OUTLETS
- (D) WATER HEATER
- (E) BATTERY CHARGER

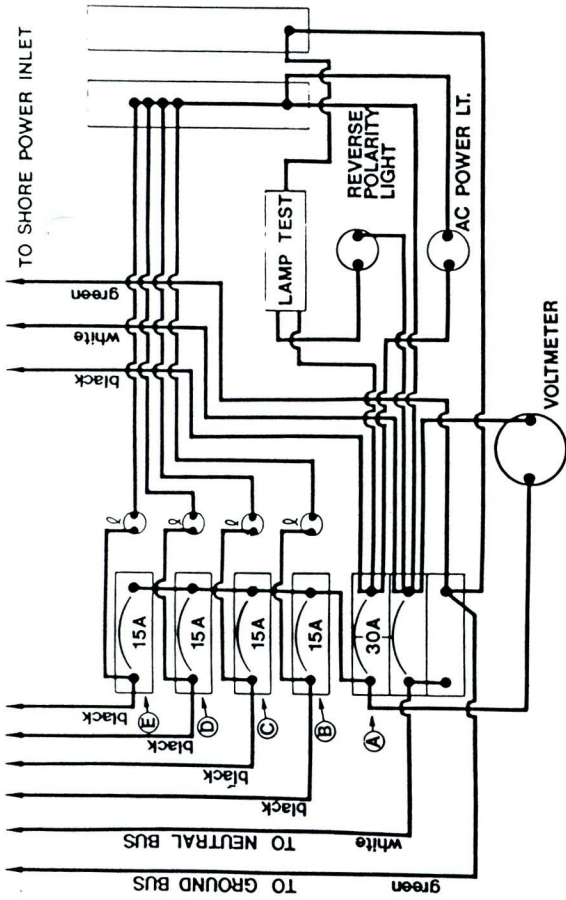

AC WIRING DIAGRAM

OUTLETS



- 10AWG-3 WIRE FROM EQUIPMENT
- BLACK = HOT-TO PANEL
- WHITE = NEUTRAL-TO NEUTRAL BUS
- GREEN = GROUND-TO GROUND BUS

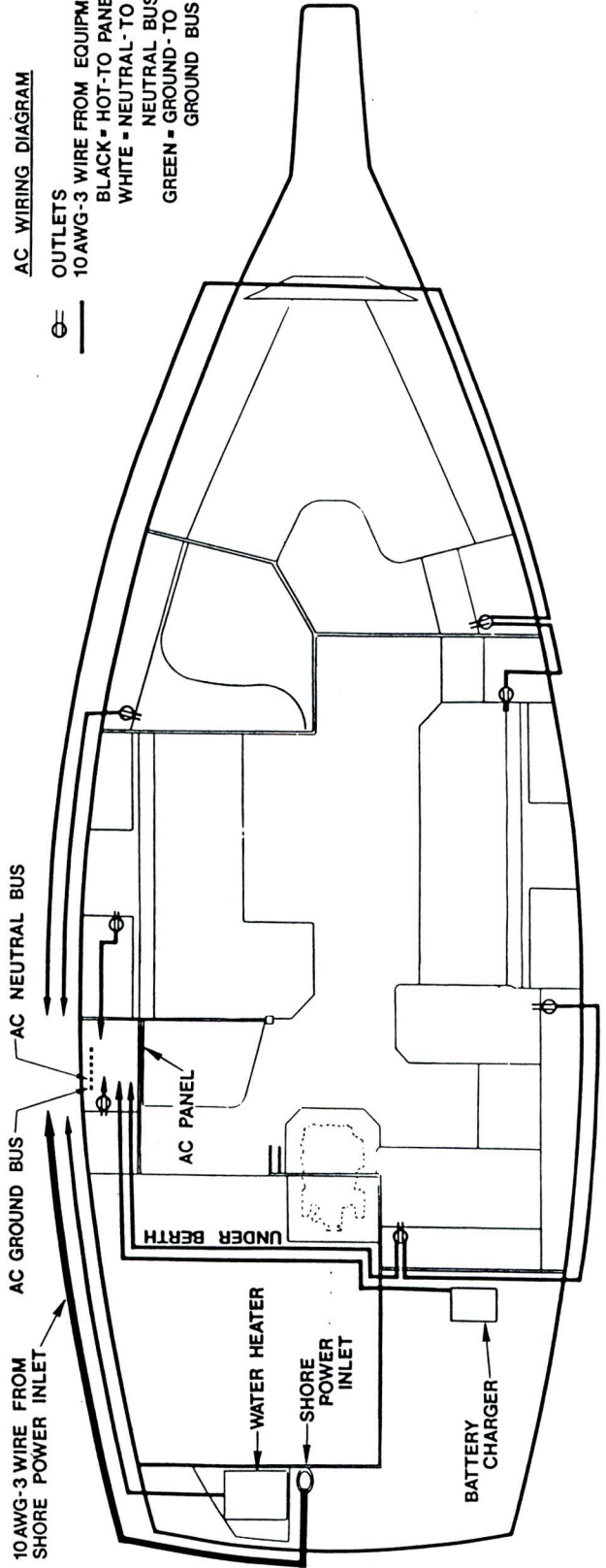

BASIC D.C. SCHEMATIC

BREAKER IDENTIFICATION:

- (A) PORT CABIN LTS., CHART LT.
- (B) STARBOARD CABIN LTS.
- (C) WATER PRESS. SHOWER DRAIN
- (D) INSTRUMENTS
- (E) RADIO
- (F) LPG
- (G) ICEBOX DRAIN PUMP
- (H) MASTHEAD LT.
- (I) BOW LT.
- (J) FOREDECK LT.
- (K) RUNNING LTS.

*NOTE: THE INDICATOR LIGHTS ARE FOR CONVENIENCE AND DO NOT SHOW WHETHER THE ACTUAL LIGHT IS LIT

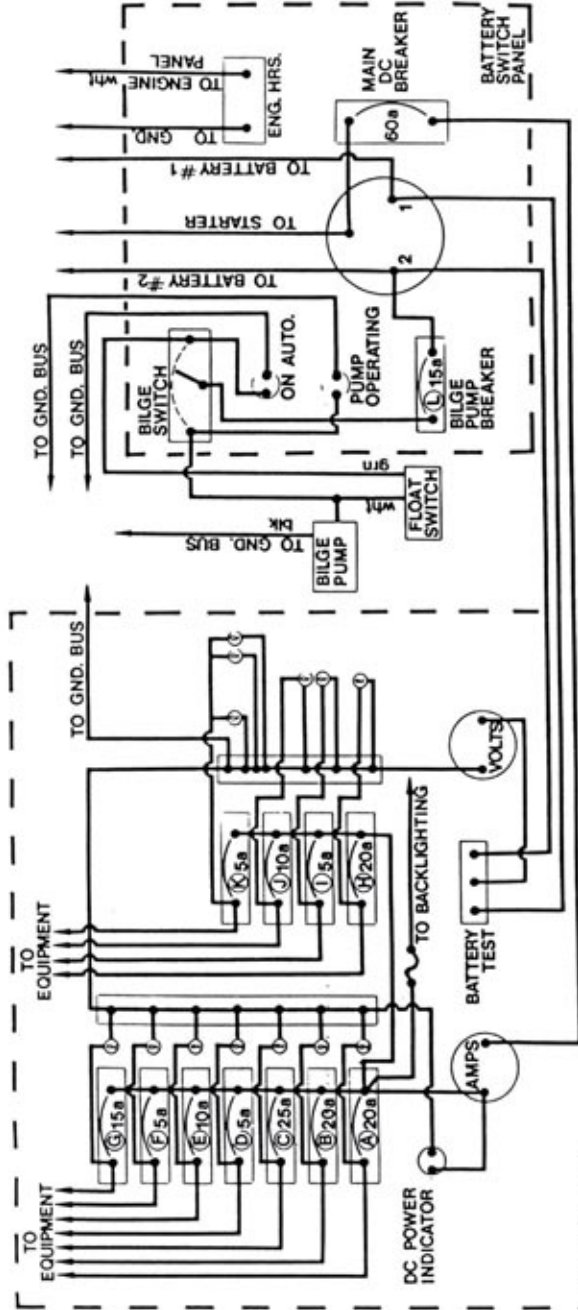

D.C. WIRING DIAGRAM

- CABIN LIGHTS
- 14 AWG WIRE:
 - RED: POSITIVE TO PANEL
 - YELLOW: NEGATIVE TO GROUND BUS
 (unless otherwise noted)

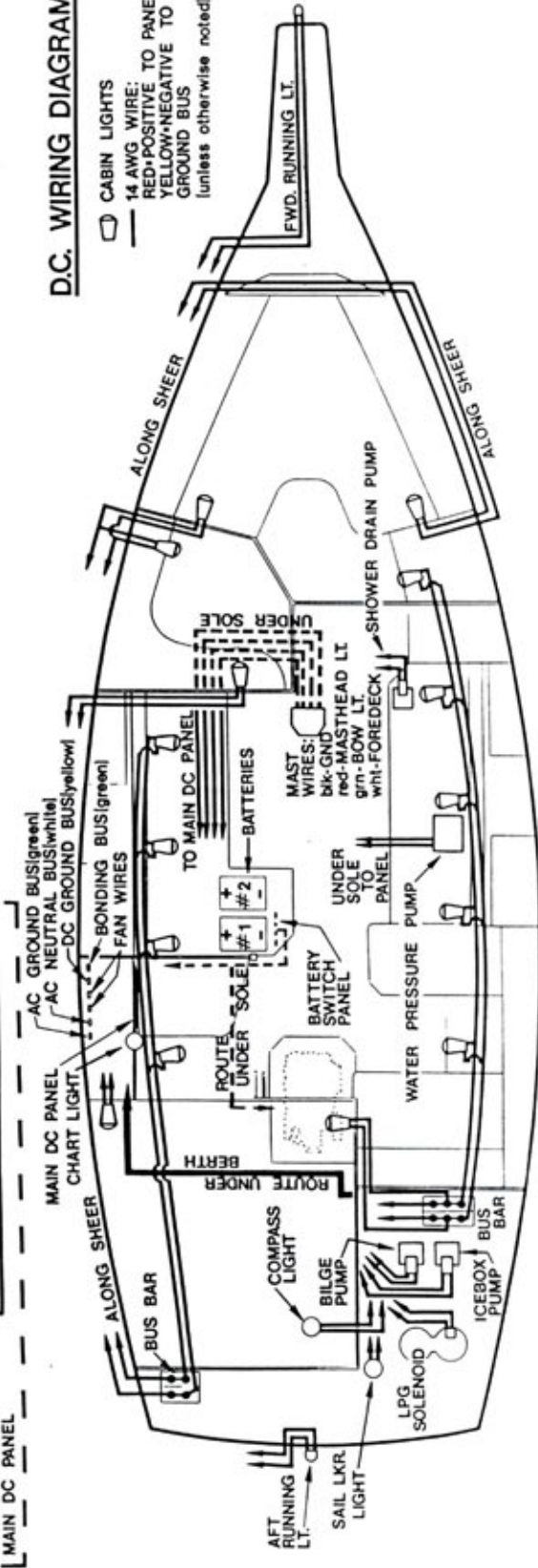

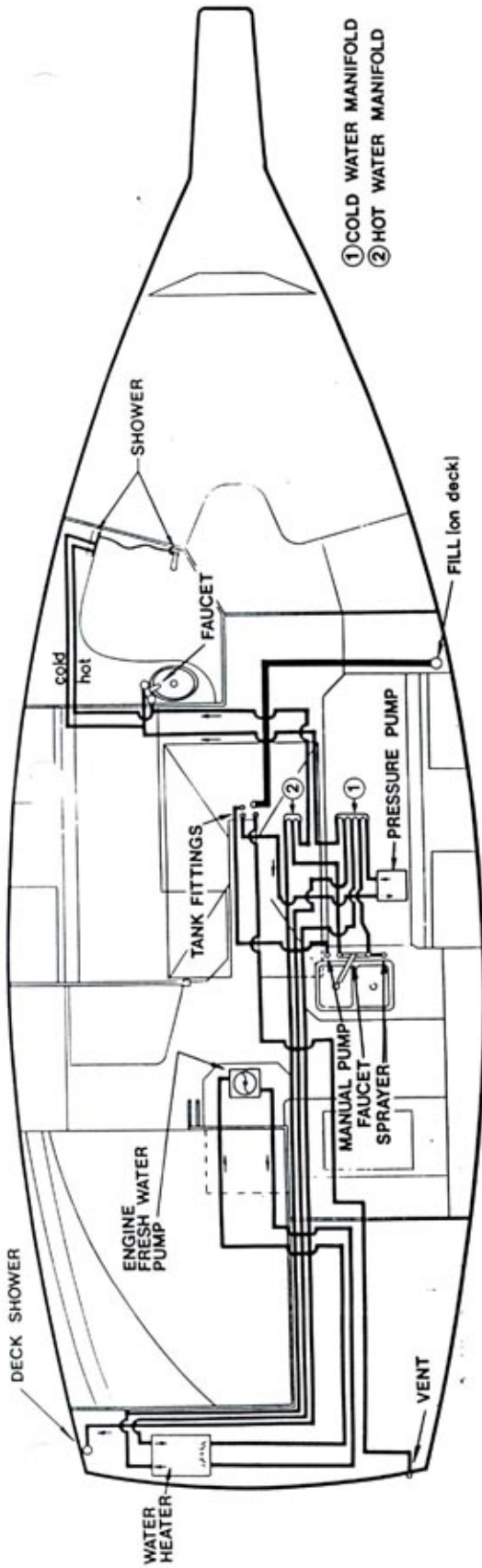

FRESH WATER SYSTEM
ISLAND PACKET 32

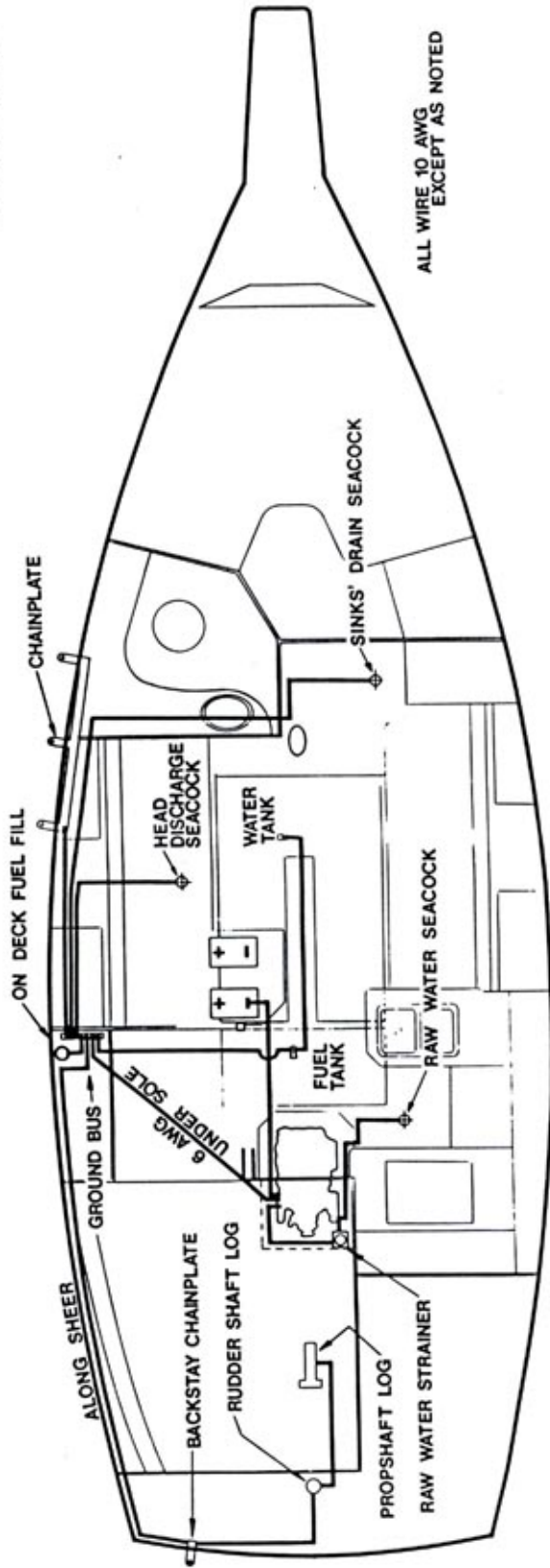

ALL WIRE 10 AWG
EXCEPT AS NOTED

BONDING SYSTEM
ISLAND PACKET 32

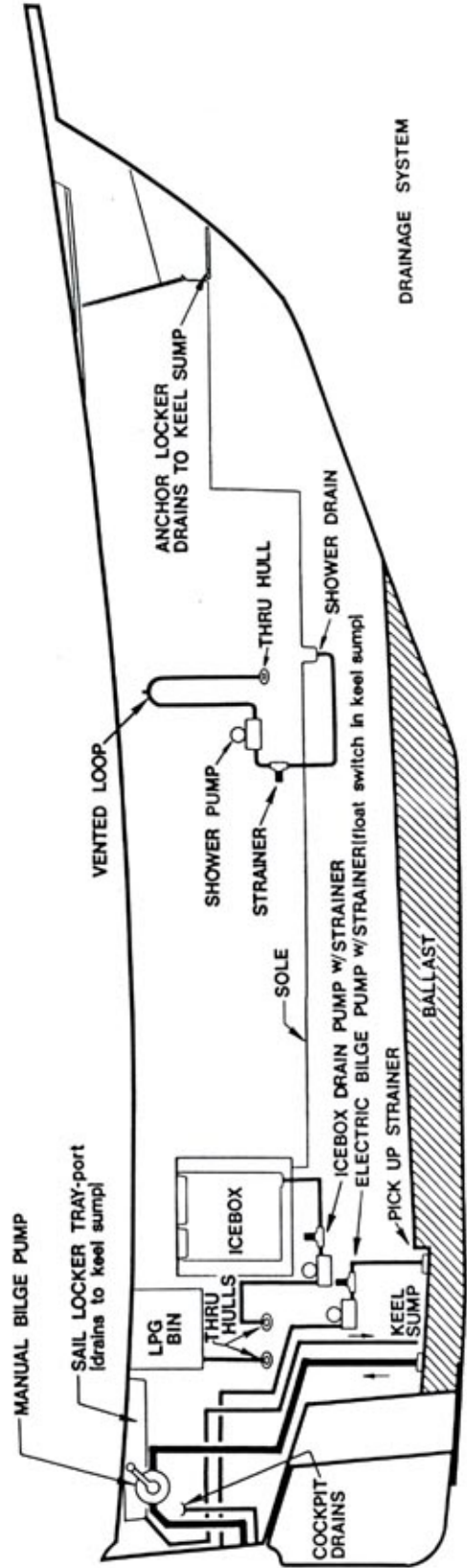
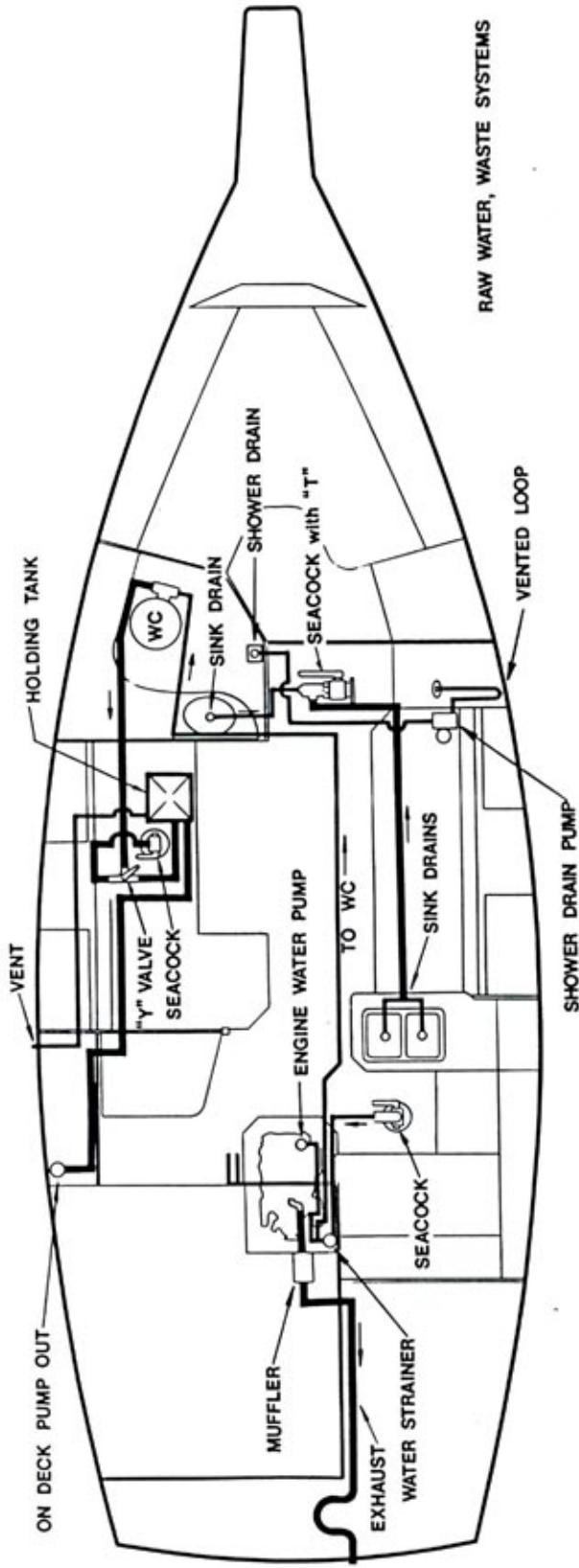

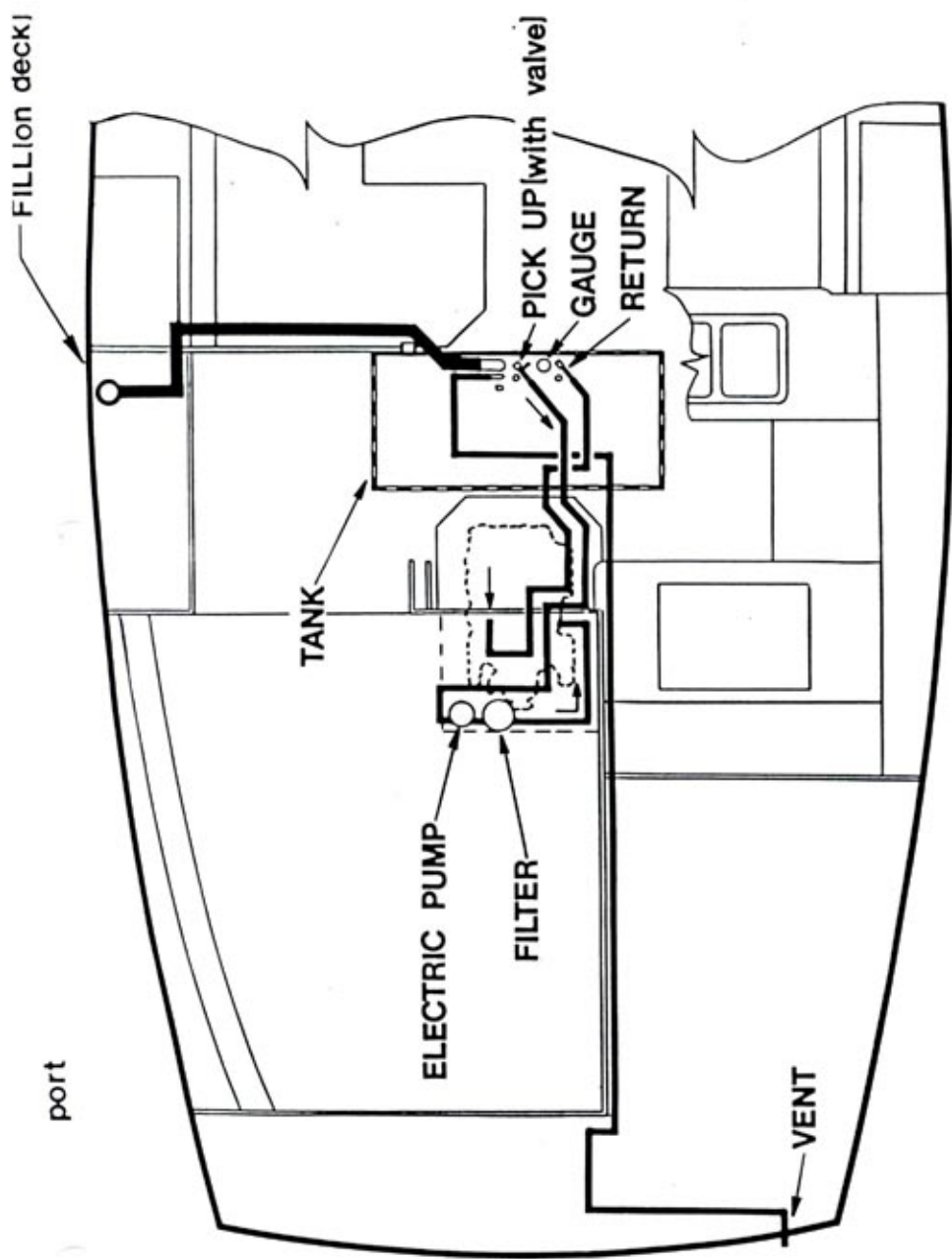

FUEL SYSTEM

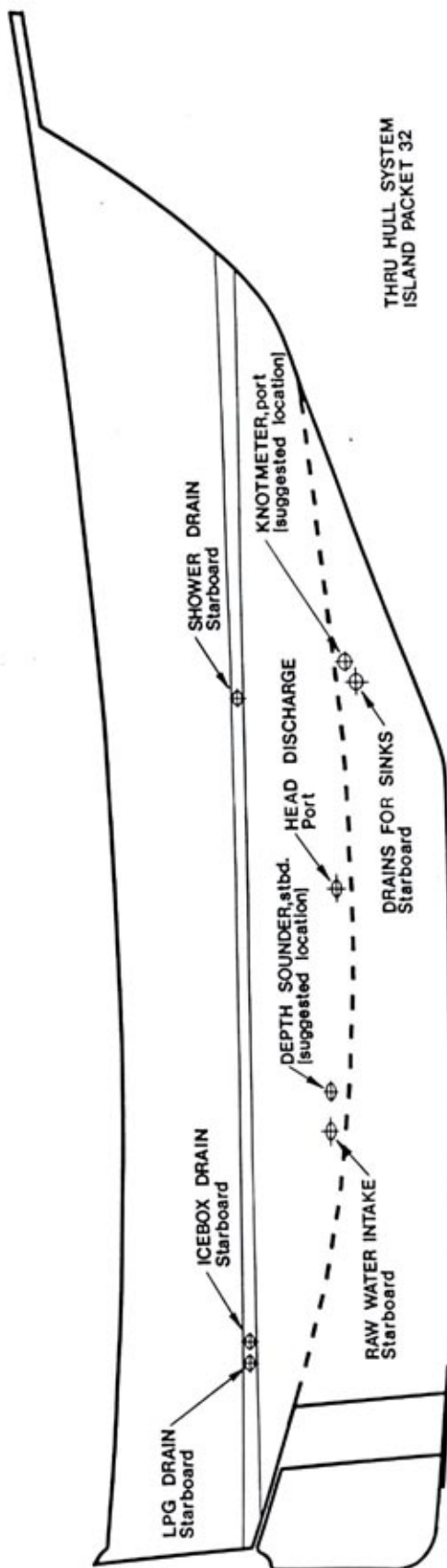
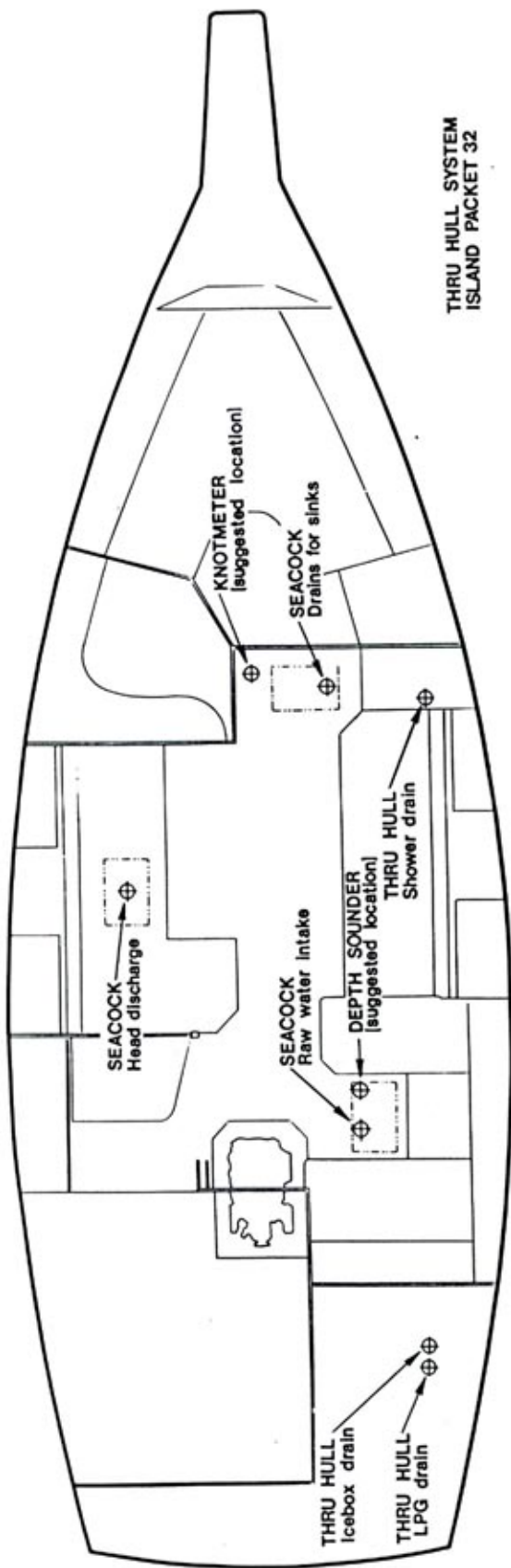

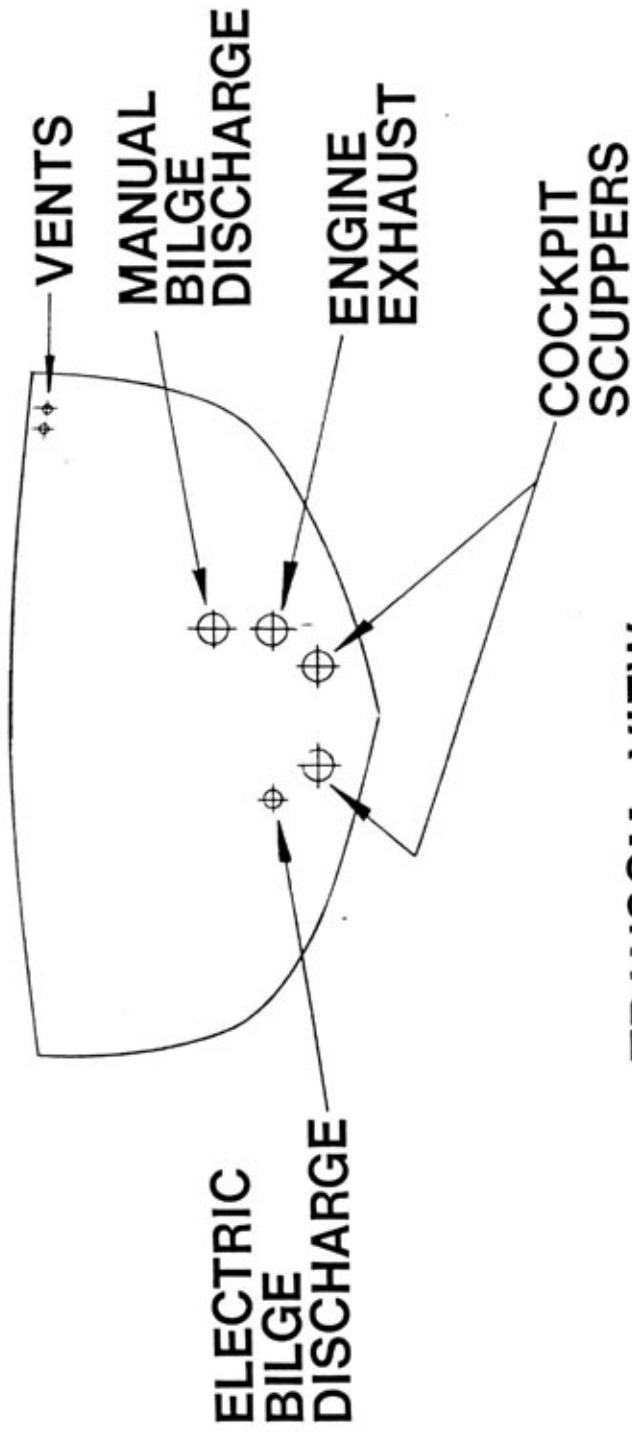

TRANSOM VIEW

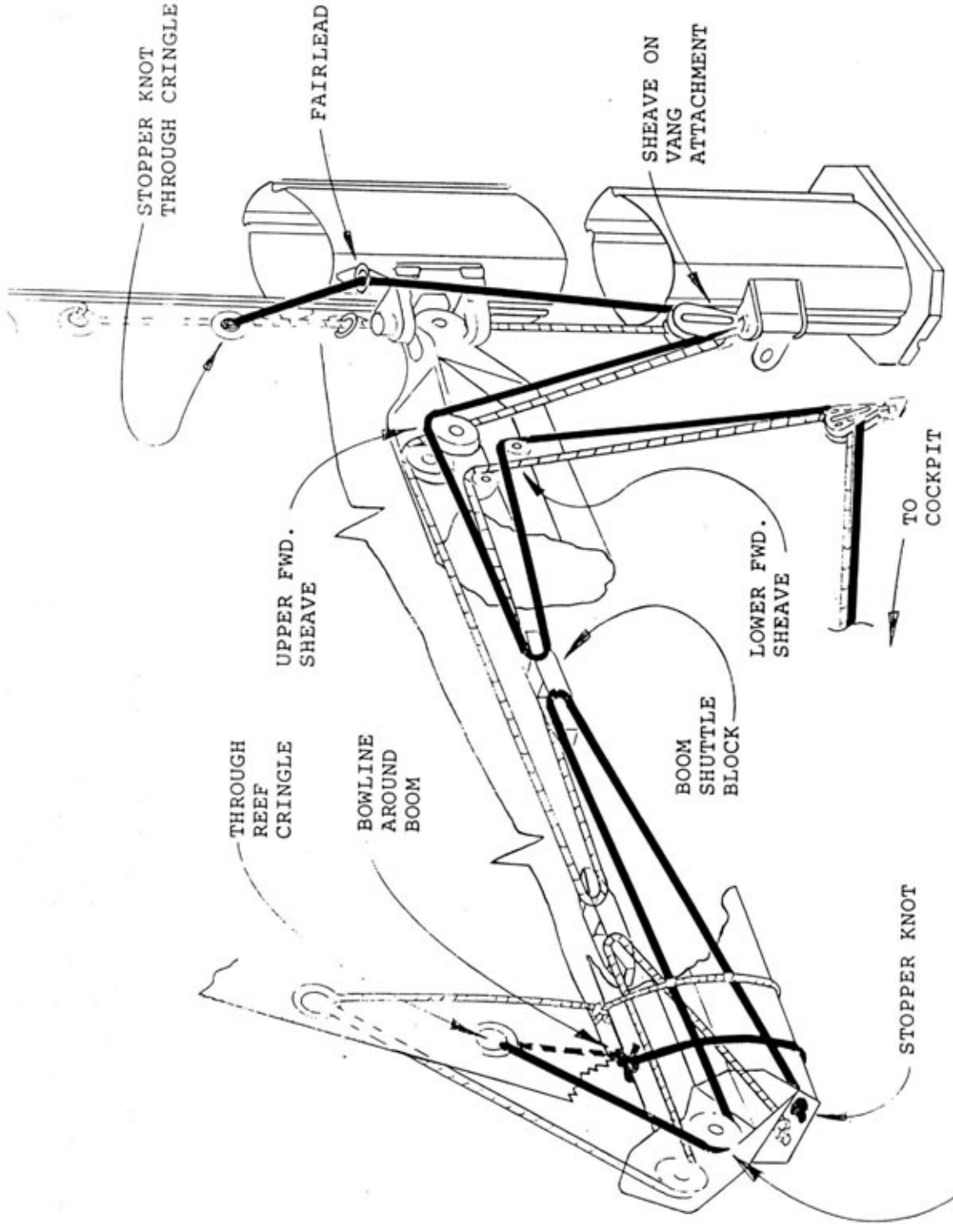

STOPPER KNOT
THROUGH CRINGLE

FAIRLEAD

SHEAVE ON
VANG
ATTACHMENT

UPPER FWD.
SHEAVE

LOWER FWD.
SHEAVE

TO
COCKPIT

THROUGH
REEF
CRINGLE

BOWLINE
AROUND
BOOM

BOOM
SHUTTLE
BLOCK

STOPPER KNOT

EXTERNAL SHEAVE

ISLAND PACKET LIGHT UNITS

<u>Location</u>	<u>Supplier</u>	<u>Part #</u>	<u>Phone Number</u>
Cabin	Progressive Dynamics	PD767UT	616-781-4241
Sail Locker	JJM	2126S	813-539-1918
Running Lights	Aqua Signal	3512392	312-232-6425
Stern Light	Aqua Signal	3509092	312-232-6425
Masthd Light	Aqua Signal	25-33513-002	312-232-6425
Combo Bow/Deck	Forespar	132002	714-838-9900
Chart Table	Aqua Signal	3132-002	312-232-6425

ISLAND PACKET LIGHT BULBS

<u>Location</u>	<u>Supplier</u>	<u>Part #</u>	<u>Phone Number</u>
Cabin	Progressive Dynamics	100514	616-781-4241
Sail Locker	JJM	Dome Lt. Bulb	813-539-1918
Red/Green	Aqua Signal	904-00200	312-232-6425
Running Lights			
Stern Light	Aqua Signal	904-00200	312-232-6425
Masthd Light	Aqua Signal	904-00200	312-232-6425
Combo Bow/Deck	Forespar	Bow 132025	714-838-9900
		Deck 132027	
Chart Table	Aqua Signal	904-00282	312-232-6425